

MARITIME FLOODLIGHT



Maritime Floodlight

145 lm/W

MARITIME FLOODLIGHT

Außenbeleuchtung

Outdoor lighting



MARITIME FLOODLIGHT

Das Maritime Floodlight zeichnet sich besonders durch seine anti-korrosiven Eigenschaften, hohe Widerstandskraft und lange Lebensdauer, gepaart mit hervorragender Effizienz, aus.

The Maritime Floodlight is particularly characterized by its anti-corrosive properties, high durability and long service life, coupled with excellent efficiency.

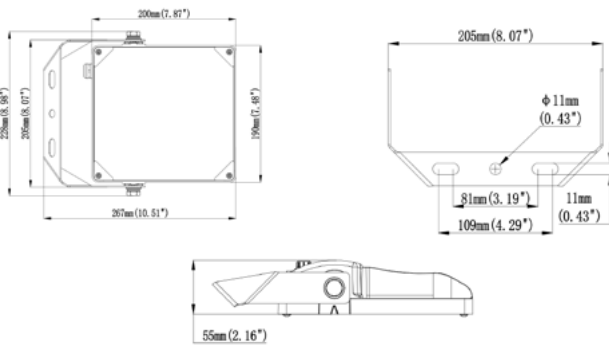

Abmessungen Maritime Series Floodlight (50W)

Dimensions Maritime Series Floodlight (50W)

5 year warranty

IP66

60,000 hours

-30 °C - +50 °C

IK08

CRI > 79



FEATURES

- » Hohe Effizienz (145lm/W)
- » 6kV Überspannungsschutz
- » 1-10V dimmbar
- » Vielseitige Anwendungen
- » Hochwertige Edelstahl-Bügel
- » Gehärtetes Glas
- » Widerstandsfähig gegen chemische Dämpfe und salzhaltige Luft
- » Anti-Korrosion-Schutz durch speziellen Aufbau der Leuchte, doppelter Pulver-Beschichtung und anti-korrosiven Schrauben
- » Druckausgleichsmembran (wird in chlorhaltigen Umgebungen durch eine spezielle Dichtung ersetzt)

ANWENDUNGSBEREICH

- » Anwendungen in Küstennähe
- » Bootswerften
- » Schwimmbäder
- » Chemische Fabriken
- » Sportplätze und Stadien
- » Einkaufszentren
- » Parkplätze

FEATURES

- » High efficiency (145lm/W)
- » 6kV surge protection
- » 1-10V dimmable
- » Versatile applications
- » High quality stainless steel bracket
- » Tempered glass
- » Resistant to chemical vapors and salty air
- » Anti-corrosion protection due to special construction of the luminaire, double powder coating and anti-corrosive screws
- » Pressure compensation diaphragm (replaced by a special seal in environments containing chlorine)

AREA OF APPLICATION

- » Near shore applications
- » Boatyards
- » Swimming pools
- » Chemical factories
- » Sports fields and stadiums
- » Shopping centers
- » Parking lots

Maritime Floodlight

Artikelnummer <i>Item N°</i>	Wattage	Lumen	Abstrahlwinkel <i>Beam Angle</i>	Abmessungen <i>Dimensions</i>	Surge protection	Energieeffizienz <i>Energy efficiency</i>
EI-FL-30-5KG2	30W	4.350lm	120°	267*228*55mm	6kV	
EI-FL-50-5KG2	50W	7.250lm	120°	267*228*55mm	6kV	
EI-FL-75-5KG2	75W	10.875lm	120°	314*269*61mm	6kV	
EI-FL-100-5KG2	100W	14.500lm	120°	314*269*61mm	6kV	

Für alle: Farbtemperatur Standard 5.000K; Lebensdauer 60.000h L80B10; PF>0,9; CRI79; SDCM<=4 / For all: CCT standard 5,000K; Lifetime 60,000h L80B10; PF>0,9; CRI79; SDCM<=4.

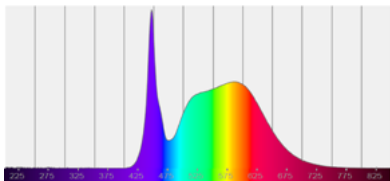

Maritime Floodlight

Alle Angaben vorbehaltlich technischer Änderungen

EiKO-Europe GmbH
Mittelwegring 20
76751 Jockgrim
Germany

C+R Automations- GmbH

Nürnberger Straße 45
90513 Zirndorf

Tel. +49 (0)911 656587-0
E-Mail: info@crautomation.de
www.crautomation.de

