

K30L2/K50L2 – LED-Multifunktionsanzeige: ProSerie

RGB-LED-Anzeigeleuchte in Kompaktbauform

 IO-Link



Ausgestattet mit RGB-LEDs bieten die Anzeigeleuchten der ProSerie K30L2 und K50L2 höchste Flexibilität und einen breiten Anwendungsbereich.

- Ansteuerung von bis zu sieben LED-Farben in der Standardeinstellung
- Parametrierung von bis zu 14 LED-Farben und Leuchtfunktionen mit der ProEditor-Software
- Bipolare Ansteuerung, kein Steuergerät erforderlich
- I/O-Block-Kompatibilität einstellbar
- Ausführungen mit IO-Link: Ansteuerung der Lichtfarben und Leuchtfunktionen via IO-Link-Schnittstelle (unbegrenzte Farbvarianten)
- Drei Signaltonger verfügbar: Dauerton (IP50), lauter Dauerton (IP50), Dauerton (IP67)
- Einfache Montage durch 22-mm bzw. 30-mm-Gewindesockel, kein Werkzeug erforderlich
- Robustes, epoxidgekapseltes Gehäuse

Typenschlüssel

K50L2 **RGB** **K** **ALS** **Q**

K50L2	Baureihe	RGB	Lichtfarbe	K	Eingang
	Baureihe K50L2 Ø 50 mm – ProSerie K30L2 Ø 30 mm – ProSerie KxxL2F ProSerie – Gehäuse FDA-konform		Lichtfarben RGB RGB-LED-Farben Multicolor		Eingang 7 mit ProEditor-Software konfigurierbar K IO-Link (nur K50L)

ALS	Akustische Signale	Q	Elektrischer Anschluss
	Akustische Signale (nur K50L) blank ohne akustische Signale A1 Signaltonger mit Dauerton (IP50) AL1 Signaltonger mit lautem Dauerton (IP50) ALS Signaltonger mit lautem Dauerton (IP67)		Elektrischer Anschluss Q Steckverbinder, M12 × 1 QP Anschlussleitung, 150 mm, mit Steckverbinder M12 × 1 blank Anschlussleitung, 2 m

Allgemeine Daten

Technische Eigenschaften	Baureihe	K30L2	K50L2	K50L2...K
	Ausführung	Standard	Standard	IO-Link
	Betriebsspannung	10...30 VDC	10...30 VDC	18...30 VDC
LED-Anzeige	Lichtfarben (max.)	14	14	unbegrenzte Farbmöglichkeiten
	Lichtfarben	grün, gelb, rot, blau, weiß, türkis, magenta, orange, bernstein, lindgrün, frühlingsgrün, himmelblau, violett, rosa		
	Leuchtfunktionen	Vielzahl von Animationen		
	max. Stromaufnahme	60 mA	220 mA	220 mA
Signaltongeber	Standard – Lautstärke	–	75 dB	75 dB
	Laut – Lautstärke	–	95 dB	95 dB
	Versiegelt – Lautstärke	–	94 dB	94 dB
	Dauerton	–	ja	ja
	Pulston	–	–	ja
	Einstellbare Intensität	–	optional	
Bauform	Leuchtfläche	Ø 30 mm, Kunststoffkuppel	Ø 50 mm, Kunststoffkuppel	
	Befestigung	M22-Gewindesockel	M30-Gewindesockel	
	Gehäusefarbe	schwarz	schwarz	
	Fenster	grau matt	grau matt	
	Schutzart	IP67/IP69K	je nach Typ: IP50/IP67/IP69K	

Auswahltable K30L2/K50L2

Typ K30L2	Ident-No.	Lichtfarben	Ansteuerung	Elektrischer Anschluss
K30L2RGB7	3802139	14 Farben	bipolar PNP/NPN mit ProEditor konfigurierbar	Anschlussleitung, 2 m, 5-polig
K30L2RGB7QP	3802141			Anschlussleitung, 150 mm, mit M12-Steckverbinder, 5-polig
K30L2FRGB7QP	3802142			Anschlussleitung, 150 mm, mit M12-Steckverbinder, 5-polig
K30L2RGB7Q	3802140			M12-Steckverbinder, 5-polig

Typ K50L2	Ident-No.	Lichtfarben	Ansteuerung	Elektrischer Anschluss
K50L2RGB7Q	3802145	14 Farben	bipolar PNP/NPN mit ProEditor konfigurierbar	M12-Steckverbinder, 5-polig
K50L2RGB7A1Q	3802148			
K50L2RGB7AL1Q	3802151			
K50L2RGB7ALSQ	3802154			
K50L2RGBKQ	3802158	unbegrenzte Farbvarianten	IO-Link	M12-Steckverbinder, 4-polig
K50L2RGBKA1Q	3802160			
K50L2RGBKAL1Q	3802162			
K50L2RGBKALSQ	3802164			

Weitere Ausführungen erhältlich (siehe Typenschlüssel)

Features

30 mm IO-Link Controlled Multicolor RGB Devices (Indicator and Touch Button)

This datasheet contains limited information on K30 Pro Devices with IO-Link. Go to www.bannerengineering.com and search 215995 to view the K30 Pro Devices IO-Link Data Reference Guide or 215996 to access the K30 Pro IODD File. Use of this document assumes familiarity with pertinent industry standards and practices.

- IO-Link gives full access to color, flashing, rotating, and dimming settings as well as advanced animations such as dynamic sequence mode and LED control
- Output settings, including on and off delays, output function, and output state are also available with IO-Link
- 18 V DC to 30 V DC operation
- Encapsulated construction option on Pro touch models for added protection against condensation and harsh environments

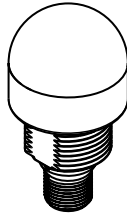

Indicator

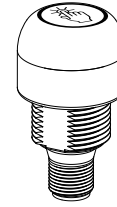

Touch Button

WARNING:



- **Do not use this device for personnel protection**
- Using this device for personnel protection could result in serious injury or death.
- This device does not include the self-checking redundant circuitry necessary to allow its use in personnel safety applications. A device failure or malfunction can cause either an energized (on) or de-energized (off) output condition.

Models

Touch Button Models

- Excellent immunity to false triggering by water spray, oils, and other foreign materials
- Rated IP67 and IP69K per DIN 40050-9
- Can be actuated with bare hands or gloves; adjustable sensitivity

Model Key for Touch Button Models

Family	Style	Activation Method	Construction	Material	Control	Connector
K30	P = Pro	T = Touch	Blank = Ultrasonically welded	Blank = Standard	K = IO-Link	Q = Integral 4-pin M12 male quick-disconnect connector
			E = Encapsulated and welded			QP = 150 mm (6 in) PVC-jacketed cable with a 4-pin M12 male quick-disconnect connector ⁽¹⁾

Indicator Models

- Bright, uniform indicator light
- Rated IP67 and IP69K per DIN 40050-9

Model Key for Indicator Models

Family	Style	Housing	Control	Connector
K30	P = Pro	L = Dome	K = IO-Link	Q = Integral 4-pin M12 male quick-disconnect connector
				QP = 150 mm (6 in) PVC-jacketed cable with a 4-pin M12 male quick-disconnect connector

⁽¹⁾ This option is required for encapsulated models.

Wiring Diagram



IO-Link®

IO-Link® is a point-to-point communication link between a master device and a sensor and/or light. It can be used to automatically parameterize sensors or lights and to transmit process data. For the latest IO-Link protocol and specifications, please visit www.io-link.com.

For the latest IODD files, please refer to the Banner Engineering Corp website at: www.bannerengineering.com.

IO-Link Process Data In (Device to Master)

Use process data to read the device output state. When the device is in Four State Full Logic mode, use process data to read the device logic state in addition to the output state.

Name	Description
Output State	Output state follows touch button input (Touch Models Only)
Device State	Current state (State 1, State 2, State 3, State 4). Only available with Operation Mode set to Four State Full Logic or Multicolor

IO-Link Process Data Out (Master to Device)

Use process data out to define device states. Use parameter data to define device modes, states, and custom colors.

Advanced Mode

Use process data to control color, intensity, flash, and other animation types. Process data is also used to control the sequence value dynamically. Use parameter data to create custom colors, intensity, speeds, and to define output and touch settings.

Four State Full Logic Mode (Touch Models Only)

Use process data to define the Job Input state and to read the touch button state and device state (State 1, State 2, State 3, State 4). See below for more information about how to achieve legacy logic types (C, D, E, and H). Use parameter data to change color, intensity, flash, speed, select animation type, and define output settings.

Multicolor Mode

Use process data to activate the defined device state. Use parameter data to define output settings, control delays, color, intensity, flash, and other animation types for State 1, State 2, State 3, and State 4.

Name	Description
Animation Type	
Off	Indicator is off
Steady	Color 1 is solid on at defined intensity
Flash	Color 1 flashes at defined speed, color intensity, and pattern
Two Color Flash	Color 1 and Color 2 flash alternately at defined speed, color intensities, and pattern
50/50	Color 1 is displayed on 50% of the indicator and Color 2 is displayed on the other 50% of the indicator at the defined color intensities
50/50 Rotate	Color 1 is displayed on 50% of the indicator and Color 2 is displayed on the other 50% of the indicator while rotating at the defined speed, color intensities, and rotational direction
Chase	Color 1 is displayed as a single spot against the background of Color 2 while rotating at the defined speed, color intensities, and rotational direction
Intensity Sweep	Color 1 repeatedly increases and decreases intensity between 0% to 100% at defined speed and color intensity
Color Sweep	Color 1 and Color 2 transition alternately at defined speed and color intensities
Sequence	Color 1 increments against the background of Color 2 at defined Dynamic or Static Sequence Value (Advanced mode and other modes respectively)
Wave	Color 2 increases in intensity on the background of Color 1 from one side of the device to the other at the defined speed

Continued on page 3

Continued from page 2

Name	Description
Animation Direction	Defines the direction of rotation for the 50/50 rotate, chase, and sequence animations (CW or CCW)
Animation Pattern	Defines the flash pattern for flash and two color flash animations (normal, strobe, three pulse, SOS, or random)
Animation Speed	Defines the animation speed (slow, medium, fast, or custom)
Dynamic/Static Sequence Value	Defines the span of Color 1 in the Sequence animation [0-255]. 0 means no portion of the animation will be Color 1, and it increases in a circular manner to 255 which indicates the full circumference will be Color 1. In Advanced Mode, this is in process data and is called Dynamic Sequence Value. In the other modes, this is in parameter data and is called Static Sequence Value.
Sequence Shift	Shifts the beginning of the sequence animation to the specified LED (LED1 at 12 o'clock continuing in the direction indicated by the Animation Direction parameter)
Color 1	Defines Color 1 of defined animation
Color 1 Intensity	Defines the intensity of Color 1 in the animation (high, medium, low, off, or custom)
Color 2	Defines Color 2 of defined animation
Color 2 Intensity	Defines the intensity of Color 2 in the animation (high, medium, low, off, or custom)

Four State Full Logic Mode State Descriptions

Use process data job input and the touch button input to dictate which one of these states the device should be in. Use parameter data to define the state characteristics.

State 1: Process Data job input off and touch button inactive

State 2: Process Data job input on and touch button inactive

State 3: Process Data job input off and touch button active

State 4: Process Data job input on and touch button active

Four State Full Logic		
	Not Actuated	Actuated
No Input	State 1	State 3
Job Input	State 2	State 4

Legacy Logic Definitions (Four State Full Logic)	
C Logic	State 1 is Off. State 2 is Color 1/Job Input. State 3 is Color 2/Acknowledge. State 4 is defined the same as State 3
D Logic	State 1 is Off. State 2 is Color 1/Job Input. State 3 is Off. State 4 is defined the same as State 2
E Logic	State 1 is Off. State 2 is Color 1/Job Input. State 3 is Color 2/Mispick. State 4 is defined the same as State 2
H Logic	State 1 is power, defined as Color 1. State 2 is defined the same as State 1. State 3 is Color 2/Sense. State 4 is defined the same as State 3

LED Control Mode

Use process data to define the color and intensity of each individual LED. Use parameter data to define customer colors and intensities. LED1 is oriented at the 12 o'clock position continuing clockwise through LED4 near 11 o'clock position.

Name	Description
LED 1 Color...LED 4 Color	Defines the color of the designated LED.
LED 1 Intensity...LED 4 Intensity	Defines the intensity of the designated LED [Values: 0-10]

Demo Mode

Cycles through color spectrum, 50/50 rotate, intensity sweep, and sequence mode. Touch button speeds cycle rate up or down (can be either Momentary or Latching). Touch button initiates state showing individually colored LEDs. When set to demo mode, the device will cycle through the defined sequence when power is applied regardless of its connection to an IO-Link master.

Touch Settings (Touch Models Only)

Use Parameter Data to define the following settings.

Setting	Description
Touch Sensitivity	Defines the sensitivity of the touch button as either Standard, High or Low. Low sensitivity resists false activation. High sensitivity can be used for improved touch response (Touch models only)
Function	Latching or Momentary Options. Momentary function toggles output on only during a touch button input. Latching function toggles output on or off for each touch button input
Mute Enable	Turning on mute disables the touch button input
On Delay (ms)	Length of time the button needs to be pressed to trigger an active state. 0-60,000 ms

Output Settings (Touch Models Only)

Use Parameter Data to define the following settings.

Setting	Description
Output State	Normally Open or Normally Closed. Normally Open turns the output on with a touch button input. Normally Closed turns the output off with a touch button input
Off Delay Type	Leading Edge or Trailing Edge. Leading Edge delays will begin once a touch button has been sensed. Trailing edge delays will begin once the touch button has been released
Off Delay (ms)	Length of time before the output state returns to a touch button inactive state after the button has been released. 0-60,000 ms

Specifications

Supply Voltage

18 V DC to 30 V DC

Supply Current

Indicator Models:

33 mA maximum current at 18 V DC

28 mA typical at 24 V DC

Touch Models:

40 mA maximum current at 18 V DC

30 mA typical at 24 V DC

Supply Protection Circuitry

Protected against reverse polarity and transient voltages

Touch Dwell Time

If touch dwells for longer than 60 seconds, the output will revert to the untouched state

Operating Conditions

-40 °C to +50 °C (-40 °F to +122 °F)

Humidity: 90% at +50 °C maximum relative humidity (non-condensing)

Storage: -40 °C to +70 °C (-40 °F to +158 °F)

Environmental Rating

IP67, IP69K per DIN 40050-9⁽¹⁾

Mounting

M22 × 1.5 threaded base, maximum torque 4.5 N·m (40 in·lbf)

Construction

Base, Dome, and Nut: Polycarbonate

Touch Response Time

Input Response: 5 ms minimum

Touch Response: 300 ms maximum (Standard Sensitivity touch response)

Vibration and Mechanical Shock

Meets IEC 60068-2-6 requirements (Vibration: 10 Hz to 55 Hz, 1.0 mm amplitude, 5 minutes sweep, 30 minutes dwell)

Meets IEC 60068-2-27 requirements (Shock: 30G 11 ms duration, half sine wave)

IO-Link Interface

Supports Smart Sensor Profile: No

Baud Rate: 38400 bps (COM2)

Process Data Out: 64 bits (8 bytes)

IODD Files: Provides all programming options, plus additional functionality

⁽¹⁾ QP models must be installed to protect the cable and cable entrance from high-pressure spray to meet IP69K.

Connections

Integral 4-pin M12 male quick-disconnect connector or 150 mm (6 in) PVC-jacketed cable with a 4-pin M12 male quick-disconnect connector, depending on model

Models with a quick disconnect require a mating cordset

Required Overcurrent Protection



WARNING: Electrical connections must be made by qualified personnel in accordance with local and national electrical codes and regulations.

Overcurrent protection is required to be provided by end product application per the supplied table.



Overcurrent protection may be provided with external fusing or via Current Limiting, Class 2 Power Supply.

Supply wiring leads < 24 AWG shall not be spliced.

For additional product support, go to www.bannerengineering.com.

Supply Wiring (AWG)	Required Overcurrent Protection (A)	Supply Wiring (AWG)	Required Overcurrent Protection (A)
20	5.0	26	1.0
22	3.0	28	0.8
24	1.0	30	0.5

Certifications

 Banner Engineering BV Park Lane, Culliganlaan 2F bus 3 1831 Diegem, BELGIUM	 cUL US LISTED
Only applies to K30PL models	Only applies to K30PL models

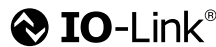

Default Indicator Characteristics

Color	Dominant Wavelength (nm) or Color Temperature (CCT)	Color Coordinates ⁽¹⁾		Lumen Output (Typical at 25 °C)		
		x	y	Touch Button Models	Indicator Models	Encapsulated Models
Green	522	0.154	0.7	7.7	8.7	6.7
Red	620	0.689	0.309	3.1	3.6	2.9
Yellow	576	0.467	0.463	7.8	8.9	7.7
Blue	466	0.14	0.054	1.7	1.9	1.3
White	5700K	0.328	0.337	9.6	10.7	9.2
Cyan	493	0.157	0.331	8.7	9.9	7.5
Magenta	–	0.392	0.186	4.2	4.6	3.9
Amber	589	0.556	0.42	5.8	6.4	5.4
Rose	–	0.525	0.237	3.5	3.9	3.3
Lime Green	562	0.383	0.523	10	11.5	8.9
Sky Blue	486	0.145	0.24	9.2	10.5	7.9
Orange	599	0.616	0.37	4.6	5.1	4.3
Violet	–	0.224	0.099	3.4	3.9	3
Spring Green	508	0.155	0.524	8	9	6.9

FCC Part 15 Class B

This equipment has been tested and found to comply with the limits for a Class B digital device, pursuant to part 15 of the FCC Rules. These limits are designed to provide reasonable protection against harmful interference in a residential installation. This equipment generates, uses and can radiate radio frequency energy and, if not installed and used in accordance with the instructions, may cause harmful interference to radio communications. However, there is no guarantee that interference will not occur in a particular installation. If this equipment does cause harmful interference to radio or television reception, which can be determined by turning the equipment off and on, the user is encouraged to try to correct the interference by one or more of the following measures:

- Reorient or relocate the receiving antenna.
- Increase the separation between the equipment and receiver.
- Connect the equipment into an outlet on a circuit different from that to which the receiver is connected.
- Consult the dealer or an experienced radio/TV technician for help.

Industry Canada ICES-003(B)

This device complies with CAN ICES-3 (B)/NMB-3(B). Operation is subject to the following two conditions: 1) This device may not cause harmful interference; and 2) This device must accept any interference received, including interference that may cause undesired operation.

Cet appareil est conforme à la norme NMB-3(B). Le fonctionnement est soumis aux deux conditions suivantes : (1) ce dispositif ne peut pas occasionner d'interférences, et (2) il doit tolérer toute interférence, y compris celles susceptibles de provoquer un fonctionnement non souhaité du dispositif.

Dimensions

All measurements are listed in millimeters [inches], unless noted otherwise.

⁽¹⁾ Refer to the CIE 1931 (x,y) Chromaticity Diagram to show equivalent color with indicated color coordinates. Actual coordinates may differ ± 5%.

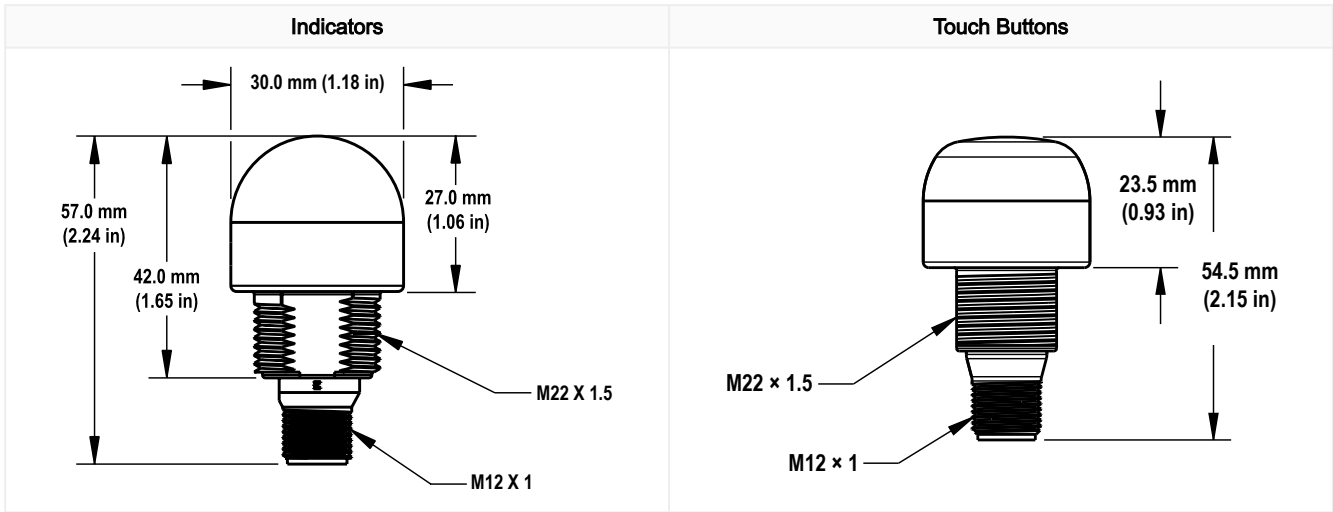

Accessories

Cordsets

4-Pin Threaded M12 Cordsets—Double Ended				
Model	Length	Style	Dimensions	Pinout
MQDEC-401SS	0.31 m (1 ft)	Male Straight/Female Straight		Female
MQDEC-403SS	0.91 m (2.99 ft)			
MQDEC-406SS	1.83 m (6 ft)			
MQDEC-412SS	3.66 m (12 ft)			
MQDEC-420SS	6.10 m (20 ft)			
MQDEC-430SS	9.14 m (30.2 ft)			
MQDEC-450SS	15.2 m (49.9 ft)			1 = Brown 2 = White 3 = Blue 4 = Black

4-Pin Threaded M12 Cordsets—Double Ended, Oil Resistant				
Model	Length	Style	Dimensions	Pinout
MQDEC-401SS-PUR	0.3 m (0.98 ft)	Male Straight/Female Straight		Female
MQDEC-403SS-PUR	1 m (3.28 ft)			
MQDEC-406SS-PUR	2 m (6.56 ft)			
MQDEC-415SS-PUR	5 m (16.4 ft)			
MQDEC-430SS-PUR	10 m (32.8 ft)			
				1 = Brown 2 = White 3 = Blue 4 = Black

4-Pin Threaded M12 Cordsets—Double Ended, Washdown, Stainless Steel				
Model	Length	Style	Dimensions	Pinout
MQDEC-WDSS-401SS	0.31 m (1 ft)	Male Straight/Female Straight		Female
MQDEC-WDSS-403SS	0.91 m (2.99 ft)			
MQDEC-WDSS-406SS	1.83 m (6 ft)			Male
MQDEC-WDSS-412SS	3.66 m (12 ft)			<p>1 = Brown 2 = White 3 = Blue 4 = Black</p>

Brackets

SMB22A

- Right-angle bracket with curved slot for versatile orientation
- 12-ga. stainless steel
- Mounting hole for 22 mm sensor

Hole center spacing: A to B = 26.0

Hole size: A = \varnothing 4.6, B = 4.6 x 16.9, C = 22.2

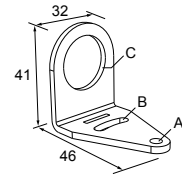

SMB22FVK

- V-clamp, flat bracket and fasteners for mounting to pipe or extensions
- Clamp accommodates 28 mm diameter tubing or 1 in. square extrusions
- 22 mm hole for mounting sensor

Hole size: A = \varnothing 22.5

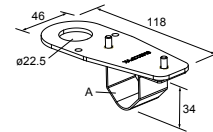

SMB22RAVK

- V-clamp, right-angle bracket and fasteners for mounting to pipe or extensions
- Clamp accommodates 28 mm diameter tubing or 1 in. square extrusions
- 22 mm hole for mounting sensor

Hole size: A = \varnothing 22.5

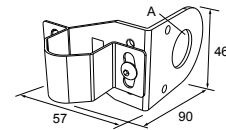

SMBAMS22P

- Flat SMBAMS series bracket with 22 mm hole for mounting sensors
- Articulation slots for 90+° rotation
- 12-ga. (2.6 mm) cold-rolled steel

Hole center spacing: A = 26.0, A to B = 13.0

Hole size: A = 26.8 x 7.0, B = \varnothing 6.5, C = \varnothing 22.5

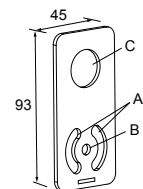

SMBAMS22RA

- Right-angle SMBAMS series bracket with 22 mm hole for mounting sensors
- Articulation slots for 90+° rotation
- 12-ga. (2.6 mm) cold-rolled steel

Hole center spacing: A = 26.0, A to B = 13.0
Hole size: A = 26.8 x 7.0, B = ø 6.5, C = ø 22.5

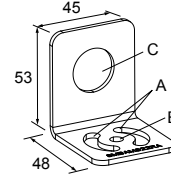

LMB22LPC

- For 28 mm tubular racking
- Toolless mount to racking
- 22 mm mounting hole

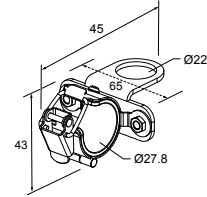

Banner Engineering Corp Limited Warranty

Banner Engineering Corp. warrants its products to be free from defects in material and workmanship for one year following the date of shipment. Banner Engineering Corp. will repair or replace, free of charge, any product of its manufacture which, at the time it is returned to the factory, is found to have been defective during the warranty period. This warranty does not cover damage or liability for misuse, abuse, or the improper application or installation of the Banner product.

THIS LIMITED WARRANTY IS EXCLUSIVE AND IN LIEU OF ALL OTHER WARRANTIES WHETHER EXPRESS OR IMPLIED (INCLUDING, WITHOUT LIMITATION, ANY WARRANTY OF MERCHANTABILITY OR FITNESS FOR A PARTICULAR PURPOSE), AND WHETHER ARISING UNDER COURSE OF PERFORMANCE, COURSE OF DEALING OR TRADE USAGE.

This Warranty is exclusive and limited to repair or, at the discretion of Banner Engineering Corp., replacement. **IN NO EVENT SHALL BANNER ENGINEERING CORP. BE LIABLE TO BUYER OR ANY OTHER PERSON OR ENTITY FOR ANY EXTRA COSTS, EXPENSES, LOSSES, LOSS OF PROFITS, OR ANY INCIDENTAL, CONSEQUENTIAL OR SPECIAL DAMAGES RESULTING FROM ANY PRODUCT DEFECT OR FROM THE USE OR INABILITY TO USE THE PRODUCT, WHETHER ARISING IN CONTRACT OR WARRANTY, STATUTE, TORT, STRICT LIABILITY, NEGLIGENCE, OR OTHERWISE.**

Banner Engineering Corp. reserves the right to change, modify or improve the design of the product without assuming any obligations or liabilities relating to any product previously manufactured by Banner Engineering Corp. Any misuse, abuse, or improper application or installation of this product or use of the product for personal protection applications when the product is identified as not intended for such purposes will void the product warranty. Any modifications to this product without prior express approval by Banner Engineering Corp will void the product warranties. All specifications published in this document are subject to change; Banner reserves the right to modify product specifications or update documentation at any time. Specifications and product information in English supersede that which is provided in any other language. For the most recent version of any documentation, refer to: www.bannerengineering.com.

For patent information, see www.bannerengineering.com/patents.

Document title: K30 Pro Devices with IO-Link Datasheet
 Part number: 215851
 Revision: D
 Original Instructions
 © Banner Engineering Corp. All rights reserved.



Features

50 mm IO-Link controlled multicolor RGB indicator with audible models

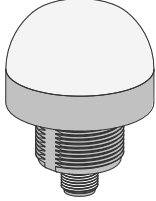
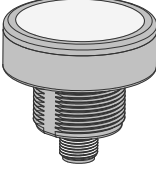
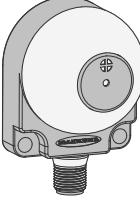
 <p>Standard model</p>	 <p>Compact model</p>	 <p>Flush-mount model</p>	<ul style="list-style-type: none"> • Bright, uniform indicator light • IO-Link control allows access to full color, flashing, and dimming controls as well as advanced animations • Millions of color possibilities • 30 mm threaded polycarbonate base • Translucent polycarbonate dome (standard models) • Compact models are available for lower profile applications • Rugged IP66, IP67, IP69K per DIN 40050-9, and UL Type 4X and UL Type 13 design • Models with integrated audible alarm available • Models constructed from FDA-grade materials available
--	---	---	---

Models

Model Key

Family	Material	Color and Input	Audible Alarm ⁽¹⁾	Connector ⁽²⁾
K50L2 = Dome	Blank = Standard	RGBK = RGB Multicolor with IO-Link	Blank = No Audible	Q = Integral 4-pin M12 male quick-disconnect connector ⁽³⁾
K50CL2 = Compact ⁽³⁾	F = FDA-grade		A1 = Audible	QP = 150 mm (6 in) PVC-jacketed cable with a 4-pin M12 male quick-disconnect connector
K50FL2 = Flush-mount ⁽³⁾			AL1 = Loud Audible ALS = Sealed Audible (IP67)	

Wiring Diagram

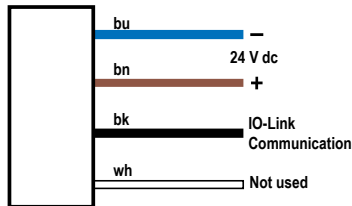

IO-Link® Process Out Data

IO-Link is a point-to-point communication link between a master device and a sensor and/or light. It can be used to automatically parameterize sensors or lights and to transmit and/or receive process data. For the latest IO-Link protocol and specifications, please visit www.io-link.com. For the latest IO-Link files, please refer to the Banner Engineering Corp website at: www.bannerengineering.com.

Process Data is transmitted cyclically to the IO-Link device from the IO-Link master. These parameters are written to the K50 acyclically and are used to perform the following functions:

- Indicator light on and off
- Audible on and off (audible models only)
- Full color control of indicator light (defined colors and ability to create custom colors)
- Full flashing control of indicator light (defined flashing rates and ability to create custom rates)
- Full dimming control of indicator light (defined intensities and ability to create custom intensities)
- Various animation control and configurability
 - Flashing: flash light at defined flash rate (50/50 duty cycle)
 - Two-Color Flashing: flash two colors at defined flash rate, alternating (50/50 duty cycle)
 - Strobe: strobe light at defined flash rate (80/20 duty cycle)
 - Half/Half: show half one color and half another color
 - Half/Half Rotate: animation that shows half one color and half another color while rotating clockwise or counter-clockwise

⁽¹⁾ Audible models are not available in FDA-grade material or compact models.

⁽²⁾ Models with a quick-disconnect connector require a mating cordset.

⁽³⁾ Compact models, flush-mount models, and models with an integral quick-disconnect connector are not available in FDA-grade materials.

- Chase: animation that shows a single spot in one color against a background of another color while rotating clockwise or counter-clockwise
- Demo Mode: cycles through defined colors and then through color spectrum

NOTE: Additional color shades can be made by adjusting intensity

IO-Link Process Data Out for the K50	
Name	Values
Color 1	Green, Red, Orange, Yellow, Lime Green, Spring Green, Cyan, Sky Blue, Blue, Violet, Magenta, Rose, White, 5 Custom Colors to define
Color 2	
Color Flash Rate (Hz)	0.5, 1.5, 3, 6, 9, 12, Custom Rate to define
Color 1 Intensity	High, Medium, Low, Custom Intensity to define
Color 2 Intensity	
Audible Mode	Off, On, Pulsed
Animation Mode	Steady, Flash, Two-Color Flash, Strobe, Half/Half, Half/Half Rotate, Chase, Demo Mode
Rotation Direction	Counter Clockwise, Clockwise

For more information see IO-Link Data Reference Guide: K50 Pro Indicator (p/n 200721).

Specifications

Supply Voltage and Current

- 24 V DC ± 25%
- 115 mA typical at 24 V DC
- 150 mA maximum at 18 V DC

Supply Protection Circuitry

Protected against reverse polarity and transient voltages

Input Response Time

30 milliseconds maximum while active

Audible Alarm

- All models have a steady tone
- A1 Model:** 75 dB at 1 m (typical), 3 kHz ± 500 Hz
- AL1 Model:** 95 dB at 1 m (typical), 2.7 kHz ± 500 Hz
- ALS Model:** 94 dB at 1 m (typical), 2.9 kHz ± 250 Hz

Connections

Integral 4-pin M12 male quick-disconnect connector, or 150 mm (6 in) PVC-jacketed cable with a 4-pin M12 male quick-disconnect connector, depending on model
Models with a quick disconnect require a mating cordset

Mounting

M30 by 1.5 threaded base, maximum torque 4.5 N·m (40 inch·lbf)
Mounting nut included

Construction

Standard and Compact Model Base, Dome, and Nut: Polycarbonate
FDA Model Base, Dome, and Nut: FDA-grade polycarbonate

Vibration and Mechanical Shock

Meets IEC 60068-2-6 requirements (Vibration: 10 Hz to 55 Hz, 1.0 mm amplitude, 5 minutes sweep, 30 minutes dwell)
Meets IEC 60068-2-27 requirements (Shock: 30G 11 ms duration, half sine wave)

Required Overcurrent Protection



WARNING: Electrical connections must be made by qualified personnel in accordance with local and national electrical codes and regulations.

Overcurrent protection is required to be provided by end product application per the supplied table.
Overcurrent protection may be provided with external fusing or via Current Limiting, Class 2 Power Supply.
Supply wiring leads < 24 AWG shall not be spliced.
For additional product support, go to www.bannerengineering.com.

Supply Wiring (AWG)	Required Overcurrent Protection (A)	Supply Wiring (AWG)	Required Overcurrent Protection (A)
20	5.0	26	1.0
22	3.0	28	0.8
24	1.0	30	0.5

Indicator Characteristics

Color	Dominant Wavelength (nm) or Color Temperature (CCT)	Color Coordinates ⁽¹⁾		Lumen Output (Typical at 25 °C) ⁽²⁾
		x	y	
Green	530 nm	0.197	0.72	20.9
Red	625 nm	0.687	0.308	5.5
Yellow	–	0.493	0.471	14.6
Blue	470 nm	0.14	0.076	5.1
Orange	–	0.612	0.372	8.1
White	5700 K	0.328	0.337	20
Cyan	–	0.164	0.35	24
Magenta	–	0.382	0.179	7.3
Lime Green	–	0.387	0.561	25.9
Spring Green	–	0.18	0.529	22
Sky Blue	–	0.155	0.25	22.8
Violet	–	0.213	0.107	8.1

⁽¹⁾ Refer to CIE 1931 chromaticity diagram or color chart, to show equivalent color with indicated color coordinates.

⁽²⁾ Values shown apply to dome models only. Compact models are 20% lower.

Color	Dominant Wavelength (nm) or Color Temperature (CCT)	Color Coordinates		Lumen Output (Typical at 25 °C)
		x	y	
Rose	–	0.507	0.231	6.2

Operating Conditions

–40 °C to +50 °C (–40 °F to +122 °F)

90% at +50 °C maximum relative humidity (non-condensing)

Storage Temperature: –40 °C to +70 °C (–40 °F to +158 °F)

Environmental Rating

Standard and Compact Models:

Non-Audible Models: IP66, IP67, IP69K per DIN 40050-9
A1 and AL1 Models: IP50

ALS Models: IP67

All Models: Meets UL Type 4X and UL Type 13 when mounted in a UL Type 4X or Type 13 enclosure

All Cabled Models also meet IP69K per DIN 40050-9 if the cable and cable entrance are protected from high-pressure spray

FDA Models: IP66, IP67, IP69K per DIN 40050-9

Certifications



FCC Part 15 Class B

This equipment has been tested and found to comply with the limits for a Class B digital device, pursuant to part 15 of the FCC Rules. These limits are designed to provide reasonable protection against harmful interference in a residential installation. This equipment generates, uses and can radiate radio frequency energy and, if not installed and used in accordance with the instructions, may cause harmful interference to radio communications. However, there is no guarantee that interference will not occur in a particular installation. If this equipment does cause harmful interference to radio or television reception, which can be determined by turning the equipment off and on, the user is encouraged to try to correct the interference by one or more of the following measures:

- Reorient or relocate the receiving antenna.
- Increase the separation between the equipment and receiver.
- Connect the equipment into an outlet on a circuit different from that to which the receiver is connected.
- Consult the dealer or an experienced radio/TV technician for help.

Industry Canada ICES-003(B)

This device complies with CAN ICES-3 (B)/NMB-3(B). Operation is subject to the following two conditions: 1) This device may not cause harmful interference; and 2) This device must accept any interference received, including interference that may cause undesired operation.

Cet appareil est conforme à la norme NMB-3(B). Le fonctionnement est soumis aux deux conditions suivantes : (1) ce dispositif ne peut pas occasionner d'interférences, et (2) il doit tolérer toute interférence, y compris celles susceptibles de provoquer un fonctionnement non souhaité du dispositif.

Dimensions

All measurements are listed in millimeters [inches], unless noted otherwise.

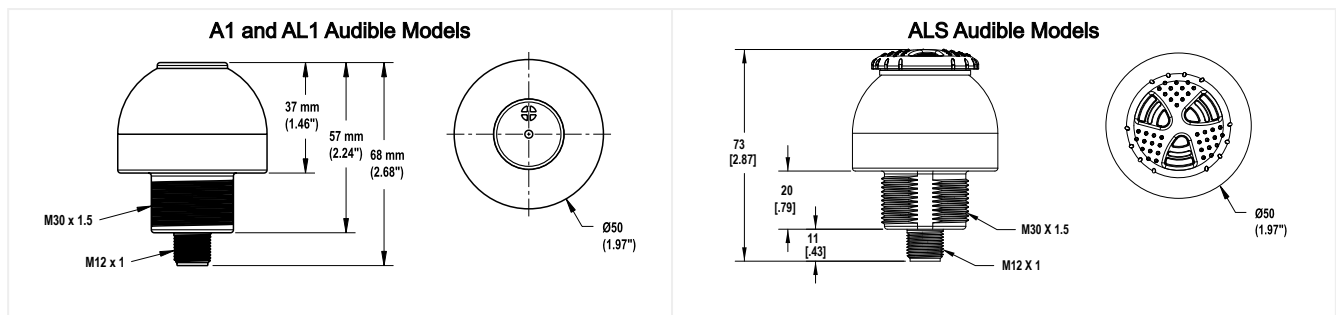

Continued on page 4

Continued from page 3

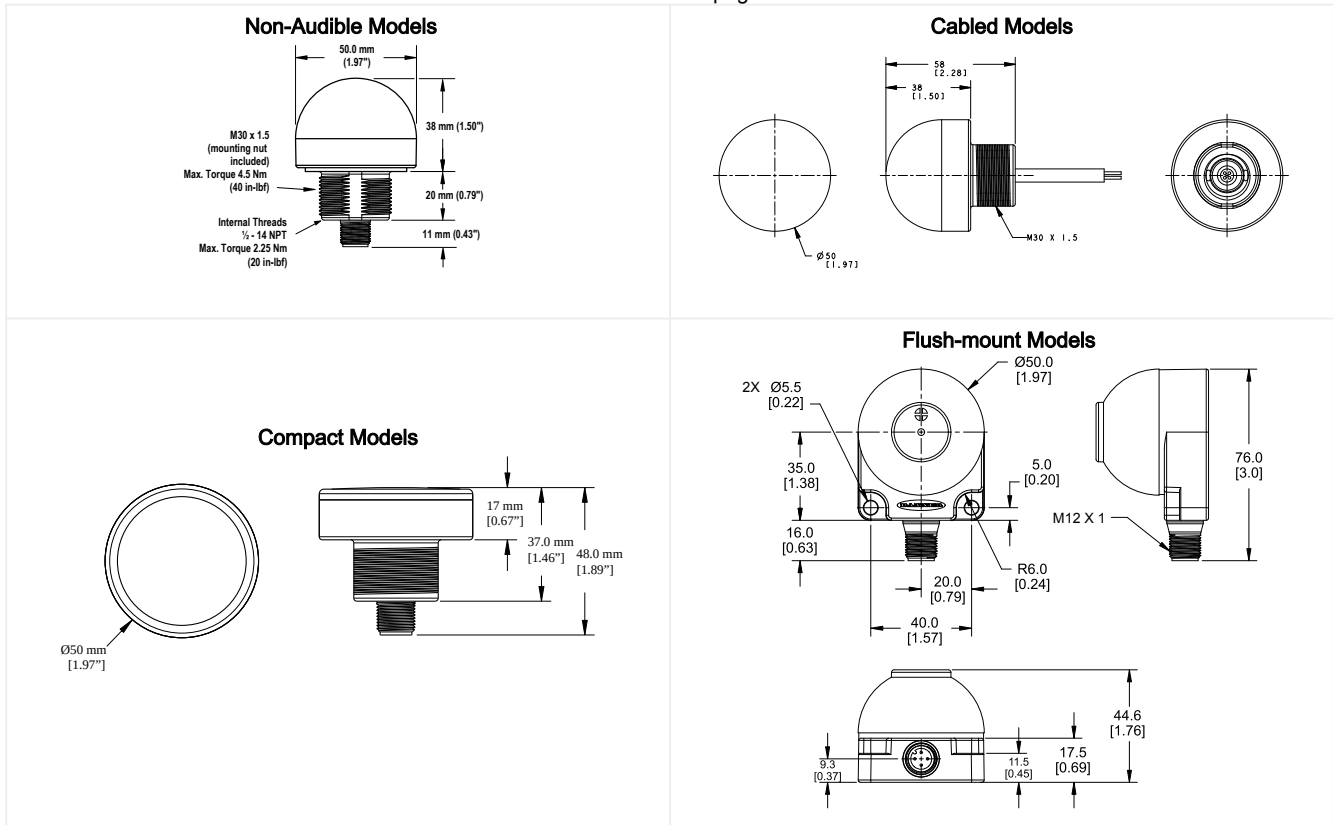

Accessories

Cordsets

4-Pin Threaded M12 Cordsets—Double Ended				
Model	Length	Style	Dimensions	Pinout
MQDEC-401SS	0.31 m (1 ft)	Male Straight/Female Straight		Female
MQDEC-403SS	0.91 m (2.99 ft)			Male
MQDEC-406SS	1.83 m (6 ft)			
MQDEC-412SS	3.66 m (12 ft)			
MQDEC-420SS	6.10 m (20 ft)			
MQDEC-430SS	9.14 m (30.2 ft)			
MQDEC-450SS	15.2 m (49.9 ft)			1 = Brown 2 = White 3 = Blue 4 = Black

Brackets

SMB30A

- Right-angle bracket with curved slot for versatile orientation
- Clearance for M6 (¼ in) hardware
- Mounting hole for 30 mm sensor
- 12-gauge stainless steel

Hole center spacing: A to B=40

Hole size: A=∅ 6.3, B= 27.1 × 6.3, C=∅ 30.5

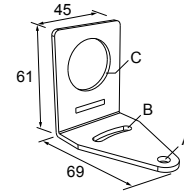

SMB30FVK

- V-clamp, flat bracket and fasteners for mounting to pipe or extensions
- Clamp accommodates 28 mm dia. tubing or 1 in. square extrusions
- 30 mm hole for mounting sensors

Hole size: A= ∅ 31

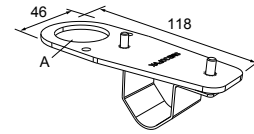

SMB30RAVK

- V-clamp, right-angle bracket and fasteners for mounting sensors to pipe or extrusion
- Clamp accommodates 28 mm dia. tubing or 1 in. square extrusions
- 30 mm hole for mounting sensors

Hole size: A = ∅ 30.5

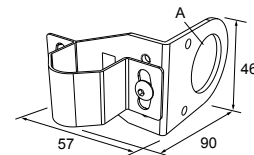

SMBAMS30P

- Flat SMBAMS series bracket
- 30 mm hole for mounting sensors
- Articulation slots for 90°+ rotation
- 12-gauge 300 series stainless steel

Hole center spacing: A=26.0, A to B=13.0

Hole size: A=26.8 × 7.0, B=∅ 6.5, C=∅ 31.0

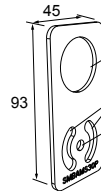

SMBAMS30RA

- Right-angle SMBAMS series bracket
- 30 mm hole for mounting sensors
- Articulation slots for 90°+ rotation
- 12-gauge (2.6 mm) cold-rolled steel

Hole center spacing: A=26.0, A to B=13.0

Hole size: A=26.8 × 7.0, B=∅ 6.5, C=∅ 31.0

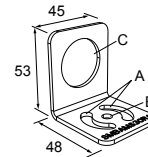

SMB30MM

- 12-gauge stainless steel bracket with curved mounting slots for versatile orientation
- Clearance for M6 (¼ in) hardware
- Mounting hole for 30 mm sensor

Hole center spacing: A = 51, A to B = 25.4

Hole size: A = 42.6 × 7, B = ∅ 6.4, C = ∅ 30.1

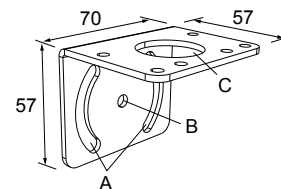

SMB30SC

- Swivel bracket with 30 mm mounting hole for sensor
- Black reinforced thermoplastic polyester
- Stainless steel mounting and swivel locking hardware included

Hole center spacing: A=∅ 50.8

Hole size: A=∅ 7.0, B=∅ 30.0

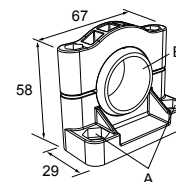

SMB30FA

- Swivel bracket with tilt and pan movement for precise adjustment
- Mounting hole for 30 mm sensor
- 12-gauge 304 stainless steel
- Easy sensor mounting to extrude rail T-slot
- Metric- and inch-size bolt available

Bolt thread: SMB30FA, A= 3/8 - 16 × 2 in; SMB30FAM10, A= M10 - 1.5 × 50
Hole size: B= ø 30.1

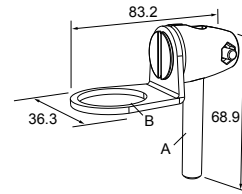

LMBE12RA35

- Direct mounting of stand-off pipe, with common bracket type
- Zinc-plated steel
- 1/2-14 NPSM nut
- Mounting distance from the wall to the center of the 1/2-14 NPSM nut is 35 mm

Hole center spacing: 20.0

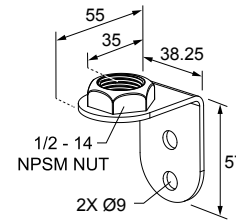

LMBE12RA45

- Direct mounting of stand-off pipe, with common bracket type
- Zinc-plated steel
- 1/2-14 NPSM nut
- Mounting distance from the wall to the center of the 1/2-14 NPSM nut is 45 mm

Hole center spacing: 35.0

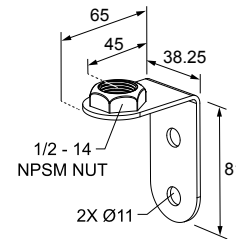

All measurements are listed in millimeters [inches], unless noted otherwise.

Banner Engineering Corp Limited Warranty

Banner Engineering Corp. warrants its products to be free from defects in material and workmanship for one year following the date of shipment. Banner Engineering Corp. will repair or replace, free of charge, any product of its manufacture which, at the time it is returned to the factory, is found to have been defective during the warranty period. This warranty does not cover damage or liability for misuse, abuse, or the improper application or installation of the Banner product.

THIS LIMITED WARRANTY IS EXCLUSIVE AND IN LIEU OF ALL OTHER WARRANTIES WHETHER EXPRESS OR IMPLIED (INCLUDING, WITHOUT LIMITATION, ANY WARRANTY OF MERCHANTABILITY OR FITNESS FOR A PARTICULAR PURPOSE), AND WHETHER ARISING UNDER COURSE OF PERFORMANCE, COURSE OF DEALING OR TRADE USAGE.

This Warranty is exclusive and limited to repair or, at the discretion of Banner Engineering Corp., replacement. **IN NO EVENT SHALL BANNER ENGINEERING CORP. BE LIABLE TO BUYER OR ANY OTHER PERSON OR ENTITY FOR ANY EXTRA COSTS, EXPENSES, LOSSES, LOSS OF PROFITS, OR ANY INCIDENTAL, CONSEQUENTIAL OR SPECIAL DAMAGES RESULTING FROM ANY PRODUCT DEFECT OR FROM THE USE OR INABILITY TO USE THE PRODUCT, WHETHER ARISING IN CONTRACT OR WARRANTY, STATUTE, TORT, STRICT LIABILITY, NEGLIGENCE, OR OTHERWISE.**

Banner Engineering Corp. reserves the right to change, modify or improve the design of the product without assuming any obligations or liabilities relating to any product previously manufactured by Banner Engineering Corp. Any misuse, abuse, or improper application or installation of this product or use of the product for personal protection applications when the product is identified as not intended for such purposes will void the product warranty. Any modifications to this product without prior express approval by Banner Engineering Corp will void the product warranties. All specifications published in this document are subject to change; Banner reserves the right to modify product specifications or update documentation at any time. Specifications and product information in English supersede that which is provided in any other language. For the most recent version of any documentation, refer to: www.bannerengineering.com.

For patent information, see www.bannerengineering.com/patents.

Document title: K50 Pro Indicator with IO-Link
 Part number: 197816
 Revision: G
 Original Instructions
 © Banner Engineering Corp. All rights reserved.

